

# FRANKE FILTERFLOW FILTER SYSTEM

Installation Guide & Technical Information

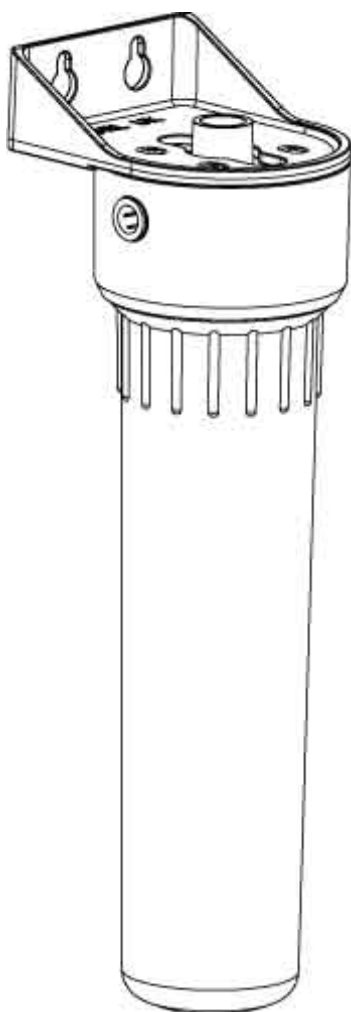

**Important Note:** This FilterFlow system is only suitable for installation with the following Franke FilterFlow taps:

Atessa Chrome	120.0486.421
Atessa SilkSteel	120.0486.422
Salara Chrome	120.0486.390
Larino Classic Silk Steel	120.0486.423

Please retain for future reference

*Make  
it  
Wonderful*

**FRANKE**

# Thank you for purchasing a Franke FilterFlow water filter system

Your Franke FilterFlow water filter system is designed to connect exclusively to Franke FilterFlow Atessa, Larino & Salara filtered water dispenser taps. The component parts of the system are precision manufactured to the highest quality standard, using premium food grade materials. Correctly installed and maintained your FilterFlow water filter will provide many years of trouble free use and a convenient, secure supply of high quality drinking water. Your Franke FilterFlow is supplied as a complete system with the parts required for connection to your Franke Atessa, Larino or Salara dispenser tap and the cold mains water, including a Franke multi-stage filter cartridge.

## Replacement Filter Cartridges

We recommend that only genuine replacement cartridges and spare parts are used to service your Franke Filterflow.

Buy replacement filter cartridges, spares and accessories at [www.frankefilterflow.co.uk](http://www.frankefilterflow.co.uk) or call **01603 875 468**.

## Filter Cartridge Replacement Period

Franke FilterFlow cartridges should be replaced at 6 monthly intervals to maintain their filtration performance.

The lifespan of the limescale reduction aspect of the cartridge depends on the hardness of the local water supply and the volume of water used. Based on average usage in hard water areas the limescale reduction should last for 3-4 months.

## Register your Franke FilterFlow

We invite you to register your FilterFlow purchase to access our free cartridge replacement reminder service and direct debit scheme.

Register online at [www.frankefilterflow.co.uk](http://www.frankefilterflow.co.uk), return the FREEPOST card provided or call **01603 875 468**. Alternatively, you can register your FilterFlow system using our App. Simply search Franke FilterFlow on the App Store or Google Play.



## SECTION 1: HOW THE SYSTEM OPERATES

The Franke 06 water filter cartridge supplied as standard with your FilterFlow is capable of removing a range of possible water contaminants.

The Franke 06 cartridge combines activated carbon and ion exchange resin. This combination will reduce chlorine, heavy metals such as lead, and limescale preventing it from adhering inside your kettle and from forming a scum on the surface of hot drinks.

If you are considering carrying out the installation of your Franke FilterFlow water filter as a DIY project, we respectfully suggest you consider the risks associated with installing water appliances. Franke recommends you engage the services of a qualified installer to install and commission your Franke FilterFlow system.

Please keep this guide in a safe place. It will enable you to get the best performance from your Franke FilterFlow filter now and in the future.

## SECTION 2: IMPORTANT THINGS TO CONSIDER

### Water Supply (Water Fittings) Regulations 1999

Familiarise yourself with the requirements of the Water Supply Regulations 1999: [www.legislation.gov.uk/ukxi/1999/1148/contents/made](http://www.legislation.gov.uk/ukxi/1999/1148/contents/made)

### Maximum Working Pressure 6 bar/90psi

Measure the pressure during the 'low demand' period, when the pressure will be at its highest eg. in the mid-morning, mid-afternoon or late evening. If the pressure exceeds 6 bar/90psi, it will be necessary to install a suitable pressure reducing valve in the supply line upstream of the filter stop valve.

Buy a suitable pressure reducing valve at [www.frankefilterflow.co.uk](http://www.frankefilterflow.co.uk)

### Minimum Pressure 1.5 bar/23psi

This is the minimum pressure recommended to achieve an acceptable flow.

### Filter Housing

The filter housing is precision engineered in ABS Plastic and will require no routine maintenance beyond regular lubrication of the large sump 'O' Seal (see Lubrication) and an occasional wipe with a damp cloth.

**IMPORTANT.** Under no circumstances should the housing come into contact with household cleaners as this may cause the housing to fracture. Plastic materials will degrade over time. Do not install the housing where it is permanently exposed to daylight, as over time extended exposure will degrade the plastic. As a precaution the housing should be replaced every 10 years.

### Taking care of the Blue Flexible Tubing

Although the tube can withstand significant water pressure, do not stretch, kink or expose the blue plastic tubing to a naked flame during installation. Do not allow the tube to come into contact with solvents and proprietary cleaners.

## SECTION 3: PLANNING YOUR INSTALLATION

Although your Franke FilterFlow system is designed for ease of installation, careful planning and preparation before commencing the installation will ensure the procedure is straightforward and trouble-free.

### Choosing the Location

Choose the most convenient place to tee into the 15mm cold water supply to install an isolation valve. Decide the best place to position the filter unit within the kitchen cabinet. Bear in mind the need for easy access to make future filter cartridge changes a simple process. Ensure the braided flexible hose and the flexible plastic tube can be fitted without stretching or kinking.

### Installing the Filter System above the Ground Floor

Extra care should be taken when installing water appliances above the ground floor. To reduce the risk of potentially catastrophic flooding, install an automatic shut-off device at the outlet of the filter stop valve.

### Backflow Prevention

To comply with UK Water Supply (Water Fittings) Regulations 1999, a suitable check valve (non-return valve) arrangement should be installed upstream of the filter stop valve.

### Lubrication

Applying a smear of grease to the large 'O' seal on the head of the housing at each cartridge change will ensure the two parts of the filter housing are easy to separate and re-assemble.

**IMPORTANT.** Use only WRAS (Water Research Advisory Service) approved silicon grease to lubricate the rubber seals as rubber and plastic parts will degrade and eventually fail if the wrong grease is used.

Buy suitable silicone grease at [www.frankefilterflow.com](http://www.frankefilterflow.com)

### Periods away from Home

If you are planning to leave the premises where the filter is installed for an extended period it is advisable to isolate the filter system. Turn off the water supply to the filter using the filter stop valve. Operate the filtered water tap on and off a few times to release the pressure in the system. When you return just turn the water supply back on and run the water for a few minutes.

### Plumbing Connections

**IMPORTANT.** To facilitate future filter cartridge changes, a suitable isolation valve must be installed in the cold Mains water feed to the filter unit (refer to diagram, section 4.)

The isolation valve must have a G 1/2" (BSP) male thread for connection to the G 1/2" (BSP) female nut at the free end of the fitted inlet hose (G).

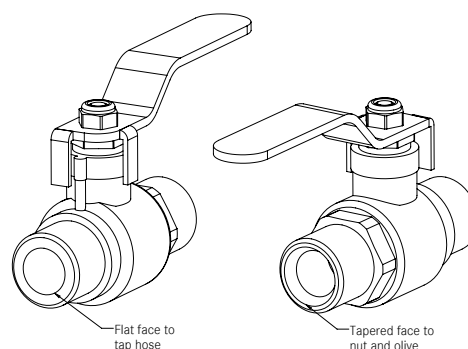
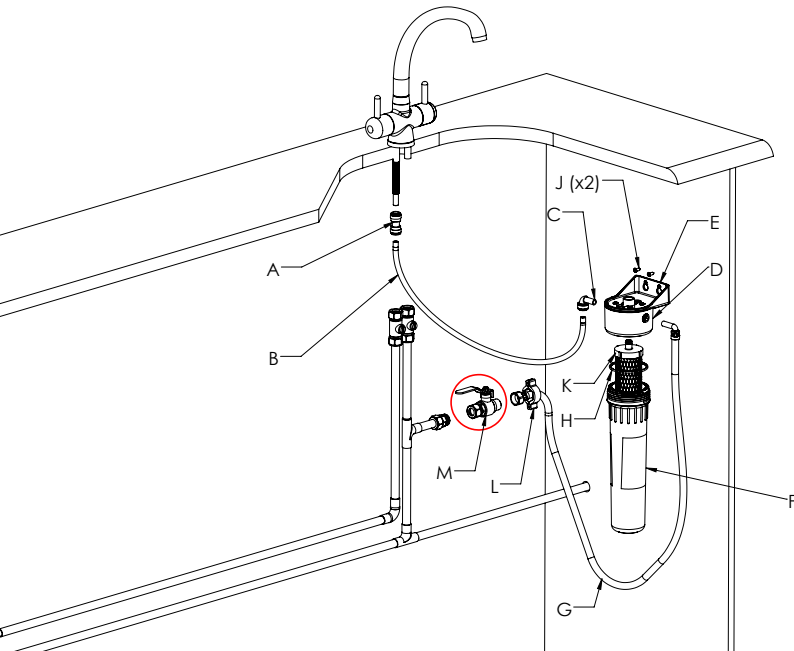

Image is for illustrative purposes only. A wide range of isolation valves are available.

**IMPORTANT.** When connecting the flexible hose to the isolation valve, hand tighten the nut firmly, using the NutRunna® provided. DO NOT TIGHTEN THE NUT WITH A SPANNER or GRIPS as doing so will RISK DAMAGING the sealing washer inside the nut.

## SECTION 4: PRINCIPAL COMPONENTS



A	3/8" x 3/8" Push-fit connector	9.03001
B	3/8" Plastic Tube	9.03110
C	3/8" Push-fit Elbow	9.03400
D	Filter Housing Head	N/A
E	Bracket	N/A
F	Sump	N/A
G	Inlet Hose	9.28001
H	'O' Seal for Filter Sump	9.07663
J	Wood Screws x 2	N/A
K	Filter Cartridge	Franke 06
L	NutRunna®	Not Supplied
M	Isolation Valve (15mm Compression x G 1/2" BSP)	Not Supplied

## SECTION 5: INSTALLATION

### Shut off the Mains Water Supply

#### Install the Isolation Valve

Install an isolation valve in the chosen position in the adjacent 15mm pipework. Please ensure the type of isolation valve you are using meets our recommended specification - see page 3

#### Secure the Filter Housing Bracket

Unscrew the housing head (D) and separate it from the sump (F). Mark the position for the two bracket supporting screws (J). Screw in both screws, leaving their heads protruding approximately 3mm to allow the bracket (E) to be easily lifted on and off the screws.

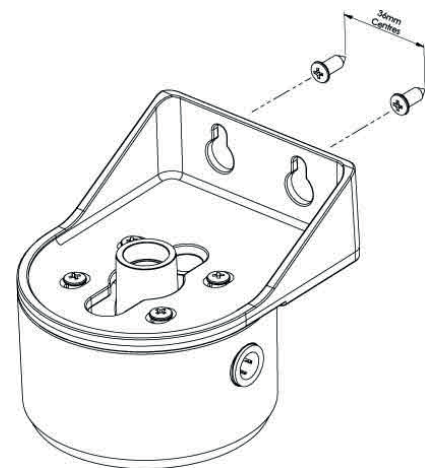

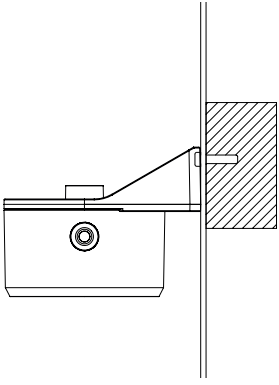

**IMPORTANT.** Depending on the nature of the cabinet it may be necessary to position a batten behind the panel to make a secure fixing. Remember the weight of the housing will increase when filled with water.

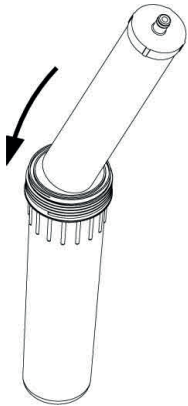

### Install the Filter Cartridge and Assemble the Filter Housing

Unpack the new filter cartridge (K) and place it in the housing sump (F) with the 'O' seal end uppermost. Screw the sump to the housing head. The cartridge will automatically engage in the head. Tighten the sump firmly sufficient to make a water tight seal.

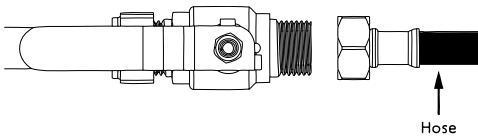

### Connect the Filter Housing to the Isolation Valve

Select the stainless steel braided inlet hose (G). Connect the end with the 1/2" BSP female nut to the male thread on the isolation valve. Tighten the nut by hand using the NutRunna<sup>®</sup> supplied.

**IMPORTANT.** Do not be tempted to use a spanner or grips as overtightening the nut will cut or cause the joint to leak.

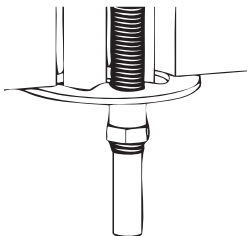

### Connect the Filter Housing to the Filter Tap

Take the grey 3/8" push-fit connector (A) fitted to the free end of the blue plastic tube (B). Locate the 3/8" diameter stem attached to the base of your FrankeFlow filter tap. Wet the stem with a little water. Engage the push fit connector on to the end of the stem and push it fully home.

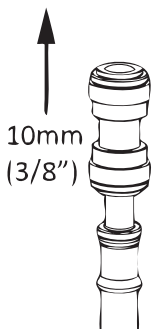

**IMPORTANT. Making the Push-Fit Connections.** Make sure that the connector is pushed fully home on the 3/8" stem. Initial resistance will be felt as the stem engages the internal 'O' seal. It is essential to continue to push the stem fully home to the final stop to make a water tight seal. The stem should enter 10mm (3/8") when fully engaged. Failure to fully engage the connector may result in a water leak or failure of the joint.

### Turn the Water On

Check to make sure all the connections are secure. Close the isolation valve and turn the lever of your filter tap to the 'ON' position. Turn on the mains water supply and turn on the isolation valve. Check that the filtered water is running from the tap spout. Allow the water to run for a minimum of 5 minutes to flush the system before drinking the filtered water.

**IMPORTANT.** The optimum flow rate is 2 litres per minute. If the flow is too fast it can be regulated by adjusting the stop valve.

### Check the Installation for Leaks

Turn off the filter tap and carefully check the whole system for leaks; particularly at the connections to the stop valve, housing and tap. Turn on the filter tap and allow the filtered water to run for approximately 10 minutes to clear any manufacturing or installation residues. Your Franke FilterFlow water filter is now ready to use (as a precaution we recommend checking for leaks again before retiring for the night).

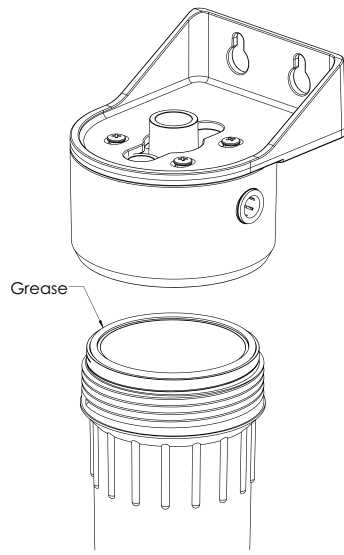

## SECTION 6: MAINTENANCE

### Routine Maintenance

Apart from the scheduled filter cartridge replacement, the filter unit will require very little routine maintenance, beyond occasional lubrication of the head 'O' Seal (K).

**IMPORTANT.** Use only WRAS approved silicon grease for this purpose - an approved grease is available to purchase from Franke FilterFlow; visit [www.frankefilterflow.co.uk](http://www.frankefilterflow.co.uk) or contact customer service on **01603 875 468**.

## SECTION 7: CHANGING THE CARTRIDGE IN YOUR FRANKE FILTERFLOW

### Cartridge Replacement Cycle

The recommended filter cartridge change cycle is 6 months.

**IMPORTANT.** The period between cartridge replacements is not guaranteed; it is an estimate based on filtering mains water of average quality. Please bear in mind that water quality changes from locality to locality and situation to situation. In very hard water areas the limescale reduction aspect of the cartridge will expire before 6 months. The length of time the filter will reduce limescale depends on the hardness of the local water supply and the volume of water used.

**Before you Begin.** No special tools are required for this operation. All you will need is a suitable receptacle to catch any spillage and a cloth or a sponge handy. A rubber glove is provided to hold the wet cartridge.

**Lubricating the Rubber Seal.** For ease of assembly we recommend that a film of silicone grease is applied to the filter housing 'O' Seal at least every other cartridge change to maintain the smooth operation of the unit.

**IMPORTANT.** Only a WRAS approved silicone lubricant should be used for this purpose.

Small tubes of WRAS approved silicone grease can be purchased from [www.frankefilterflow.co.uk](http://www.frankefilterflow.co.uk)

**Disposing of the Used Cartridge.** The carbon media in the cartridge is biodegradable, so can be recycled. You are also welcome to return the filter cartridge to FilterFlow for recycling. Should you decide upon this option, please allow the cartridge to dry naturally before returning it to us in its original packaging.

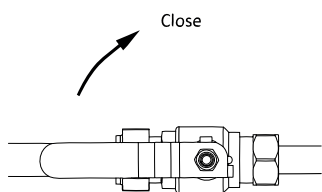

1. Locate the shut-off valve and turn off the mains water supply to the filter housing.

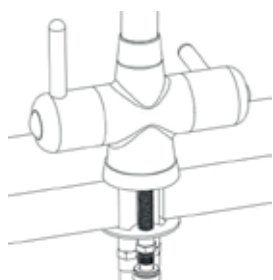

2. Activate the filtered water lever to "ON" to release the pressure in the system. Leave the tap in the on position.

**IMPORTANT.** If the tap is not left on, the pressure trapped in the system will make it impossible to unlock the head.

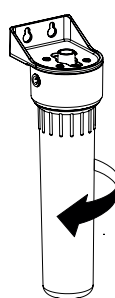

3. Firmly grip the sump with both hands. Unscrew in anti-clockwise direction and pull downwards. The sump and the filter cartridge should come away together. The filter cartridge housing will be full of water, so it is advisable to position a bowl to catch any spills.

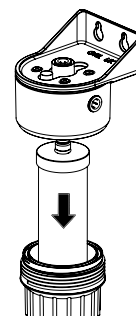

4. If the filter cartridge does not come away with the sump, release it with an index finger by pushing down on the plastic rim.

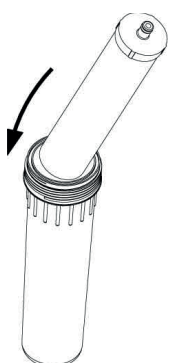

5. Holding the sump over the sink, remove the spent cartridge and empty the water in the sump. Dispose of the spent cartridge. Remove the new filter cartridge from its packaging, wet the 'O' seal and place it in the filter sump.

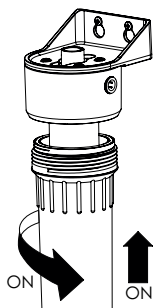

6. Position the sump, with the cartridge inside, under the filter head and screw it into place. The cartridge should engage automatically. Tighten the sump sufficiently to make a water tight seal, but take care not to overtighten. Re-mount the assembled housing on the two retaining screws.

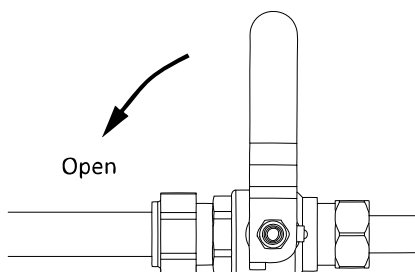

7. Turn the water supply 'on' and check the system carefully for leaks. Leave the filter tap in the 'on' position and allow the water to run for a minimum of 10 minutes to flush the system. Check the flow rate. The optimum flow rate is 2 litres per minute. If the flow is too fast it can be regulated by adjusting the stop valve.

## Warranty

### What is covered by the Franke FilterFlow guarantee?

- The repair or replacement of your drinking water filter system if your system is found to be defective due to faulty materials or within 5 years of purchase, at the discretion of Franke FilterFlow.
- If any part is no longer available or out of manufacture, Franke FilterFlow will replace it with a functional alternative.

### Terms and conditions of the Franke FilterFlow 5 year guarantee

- The guarantee is valid for the UK and Republic of Ireland.
- The guarantee becomes effective at the date of purchase (or the date of delivery if this is later).
- Proof of purchase is required under the terms of the guarantee.

This guarantee provides benefits which are additional to, and do not affect your statutory rights as a consumer.

### What is not covered by the guarantee?

- The Franke FilterFlow kitchen tap - see separate installation guide for tap warranty details.

### Franke FilterFlow does not guarantee the repair or replacement of a product as a result of:

- Normal wear and tear.
- Accidental damage, faults caused by negligent use or care, misuse, neglect, careless operation or handling of the filter system which is not in accordance with the Franke FilterFlow operating guidelines.
- Use of the filter system for anything other than normal domestic household purposes.
- Use of parts not assembled or installed in accordance with the instructions of Franke FilterFlow.
- Faulty installation, repairs or alterations (not in accordance with the installation guide).

### How do I make a claim under my Franke FilterFlow 5 year guarantee?

If you are in any doubt as to what is covered by your guarantee or wish to discuss a claim please call us on 01 603 875 468 between the hours of 9.00am and 5.00pm, Monday to Friday. If you are calling for the first time please have your receipt to hand so we can record your date of purchase.

The company reserves the right to alter, change or modify product specifications without prior notice.

Franke UK Limited  
West Park, MIOC  
Styal Road  
Manchester  
M22 5WB  
Phone +44 (0)161 436 6280  
Fax +44 (0)161 436 2180  
Email [info.uk@franke.com](mailto:info.uk@franke.com)  
**[www.franke.co.uk](http://www.franke.co.uk)**

Franke FilterFlow  
3 Old Winery Business Park  
Chapel Street  
Cawston, Norfolk  
NR10 4FE  
Phone +44 (0)1603 875 468  
Fax +44 (0)844 358 0166  
Email [info@frankefilterflow.co.uk](mailto:info@frankefilterflow.co.uk)  
**[www.frankefilterflow.co.uk](http://www.frankefilterflow.co.uk)**

